

SPHERA S29-S37 Pendant

rev. 1

Design: Matteo Thun
Codice: Sphera S29: 0703219163652
Sphera S37: 0703222163652

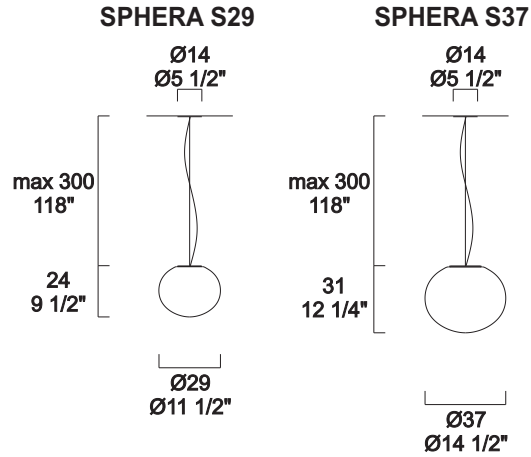

WARNING

- Before starting the wiring, joint the earth wire to the fixing bracket.
- Always unplug the appliance from the power socket before beginning installation or any sort of maintenance work.
- Use a qualified electrician for installation of this lighting fixture.
- Installation of this fixture must comply with local building codes.
- A fixture weighing more than 50lb must be mounted or supported independently of an outlet box.

INSTRUCTIONS

- Avant d'effectuer le câblage, relier le conducteur de terre à l'élément de fixation.
- Avant de procéder à l'installation de l'appareil, ainsi qu'avant toute opération d'entretien, il est nécessaire de couper le courant au disjoncteur.
- Employer un électricien qualifié pour l'installation de ce luminaire.
- L'installation de ce montage doit être conforme à codes du bâtiment locaux.
- Un montage pesant plus que 50lb doit être monté ou soutenu indépendamment d'une boîte de sortie.

ADVERTENCIAS

- Antes de realizar el cableo, acople el conductor de puesta a tierra a la brida de sujeción.
- Antes de proceder a la instalación del aparato y en cualquier caso antes de efectuar cualquier operación de mantenimiento, corte la tensión de red.
- Usar un electricista calificado para la instalación de esta luminaria.
- La instalación de este accesorio debe conformarse con códigos técnicos de la edificación locales.
- Un accesorio que pesa más que 50lb se debe montar o apoyar independientemente de una caja de enchufe.

TECHNICAL DATA

Sphera S29
1 X MAX 75W
E26 TYPE A-19 120V / 60Hz

Sphera S37
1 X MAX 100W
E26 TYPE A-19 120V / 60Hz

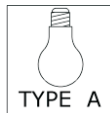

SERVIZIO AL CONSUMATORE ISTRUZIONI DI MONTAGGIO

CUSTOMER SERVICE ASSEMBLY INSTRUCTIONS

L E U C O S®

SPHERA S29-S37 Pendant

CUSTOMER SERVICE

LEUCOS USA
11 Mayfield Avenue
Edison, NJ 08837 USA
Phone (732) 225-0010 Fax (732) 225-0250
info@leucosusa.com
www.leucosusa.com



BITTE FOLGEN SIE DEN EINZELNEN SCHRITTEN DER MONTAGEANLEITUNG ENTSPRECHEND DER AUFSTIEGENDEN NUMMERIERUNG.

ESEGUIRE LE OPERAZIONI DI MONTAGGIO, SEGUENDO L'ORDINE NUMERICO PROGRESSIVO.

FOLLOW THE ASSEMBLY INSTRUCTIONS BY READING THE NUMERICAL PROGRESSION

EXÉCUTER LES OPERATIONS DE MONTAGE, EN SUIVANT L'ORDRE DE NUMÉRATION PROGRESSIF

EJECUTAR LAS OPERACIONES DEMONTAJE SIGUIENDO EL ORDEN NUMERICO PROGRESIVO

CONICAL CANOPY

1. **Fig.1.** Secure plate "A" to the J-Box with screws.
2. **Fig.1.** Guide the electrical wire through the rubber rings "Z". Then guide the fixture's electrical wires through the large opening "E" and the steel cable through the small opening "D" in the center of the plate "B".
3. **Fig.1.** Unscrew the adjustable pin "S" and guide the steel cable through it. Pin "S" has a self locking system. Push up pin "S" to unlock the steel cable. Having determined the correct height of the fixture, secure the steel cable screwing pin "S". To make sure that the fixture is well secured, place the fitting "J" at the end of the steel cable as shown.
4. **Fig.1.** Guide the electrical wire through the plastic clamp "X" then lock it with the side plastic screw.
5. **Fig.1.** Connect the fixture's electrical wires to the supply wires.
6. **Fig.1.** Slide the canopy "B" up to rest against the ceiling and secure it in position with set screw "H".
7. Install the light bulb.
8. **Fig.3** Loosen the screw "P" and install the glass diffuser. Secure the glass diffuser with the three screws "P". Each piece of glass is mouth low therefore each piece may differ. The thickness of the glass may vary slightly. In order to balance the glass diffuser, side the barrel "F" along the slotted opening and if necessary turn the glass diffuser until reaching the proper balance.
9. Restore power.

FLAT CANOPY

1. **Fig.2.** Guide the electrical wire through the rubber rings "Z". Then guide the fixture's electrical wires through the lateral opening "T" and the steel cable through the center opening "W" in the plate "R".
2. **Fig.2.** Unscrew the adjustable pin "K" and guide the steel cable through it. Pin "K" has a self locking system. Push up pin "K" to unlock the steel cable. Having determined the correct height of the fixture, secure the steel cable screwing pin "K". To make sure that the fixture is well secured, place the fitting "G" at the end of the steel cable as shown.
3. **Fig.2.** Guide the electrical wire through the plastic clamp "L" then lock it with the side plastic screw.
4. **Fig.2.** Connect the fixture's electrical wires to the supply wires.
5. **Fig.2.** Secure plate "F" to the J-Box with screws.
6. **Fig.2.** Slide the canopy "R" up to rest against plate "F".
7. Install the light bulb.
8. **Fig.3** Loosen the screw "P" and install the glass diffuser. Secure the glass diffuser with the three screws "P". Each piece of glass is mouth low therefore each piece may differ. The thickness of the glass may vary slightly. In order to balance the glass diffuser, side the barrel "F" along the slotted opening and if necessary turn the glass diffuser until reaching the proper balance.
9. Restore power.

FIG.1

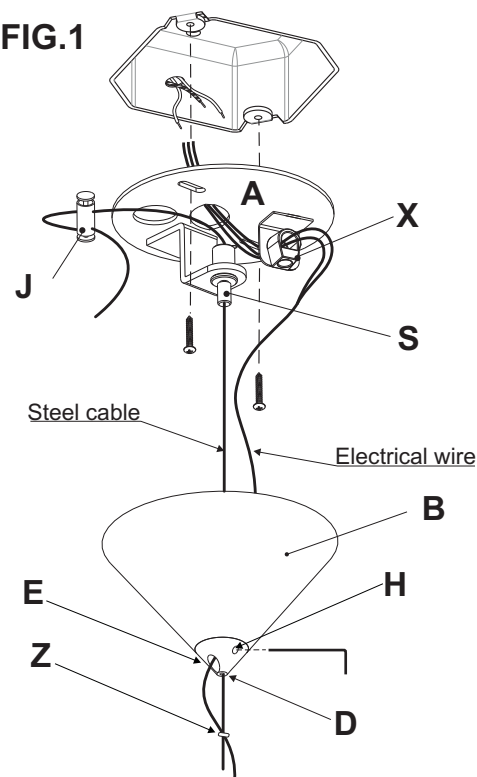

FIG.2

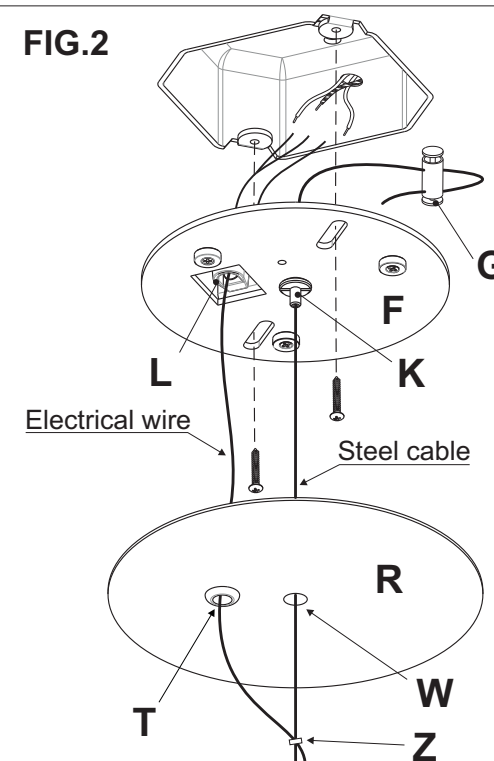
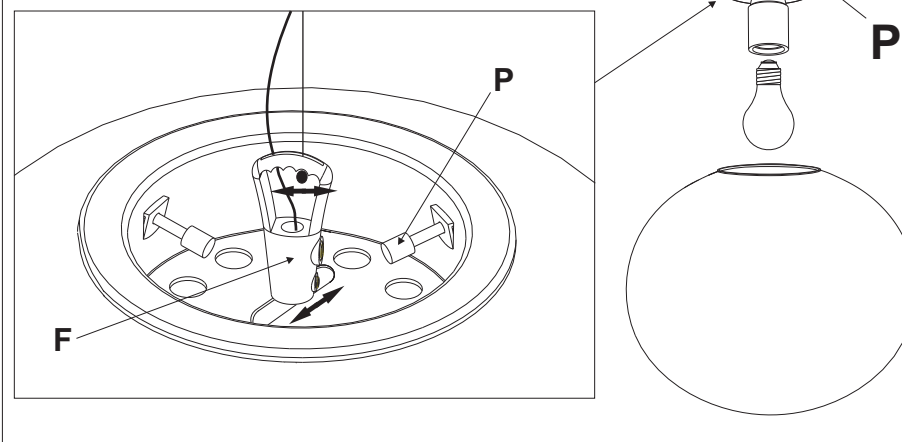

FIG.3



La sicurezza di questo apparecchio e' garantita solo con l'uso appropriato di queste istruzioni pertanto e' necessario conservarle.

The safety and reliability are guaranteed only when installation instructions are properly followed. Please retain this instruction sheet for future reference.

La securite de cet appareil n'est pas garantie en cas de non-respect de ces instructions, qu'il est necessaire de conserver.

Für die Sicherheit des Beleuchtungskörpers kann nur unter der Voraussetzung garantiert werden, daß die vorliegenden Anleitungen korrekt beachtet werden.

La seguridad del aparato se garantiza sólo utilizando de forma apropiada las siguientes instrucciones, por lo tanto es necesario conservarlas.



Montaggio 1 persona
One installer